

SIDERFLEX[®]



Steel carcass Conveyor belts



INTRODUCTION

The carcass of SIDERFLEX belts consists in a brass coated steel fabric (see picture below) with low elongation characteristics which gives to the belt a high tensile strength.

The greatest advantage of the low elongation for conveyor belts with a center distance not extremely long is the possibility to replace textile belts without significant modifications of the conveyor system. This type of carcass gives to SIDERFLEX belts special qualitative characteristics of:

- **Excellent cut and tear resistance**
 - **Low elongation**
 - **High tensile strength**
 - **Good impact resistance**
- **Excellent longitudinal flexibility**
 - **Very good troughability**



PRODUCT DESCRIPTION

WARP CHARACTERISTICS

Warp refers to longitudinal steel cords which characteristics of resistance and elasticity define the running properties of the belt.

SIDERFLEX IW – HE series, provided of open type warp cords with increased elongation, have a longitudinal elasticity bigger than the standard steel cord belts.

These performances allow to SIDERFLEX belts an easy replacement both of textile and steel cord belts.

SIDERFLEX ID serie realized with regular warp cords has the same carcass characteristics of steel cord belts according to (ex) DIN 22131 and ISO 15236-2 type A1 (see Tab. on page 8).

WEFT CHARACTERISTICS

Weft represents the whole set of transversal steel cables allowing to the belt specific resistance against cuts, tears and impacts and at the same time high flexibility.

SIDERFLEX IW – ID fabric structures are built so that one weft layer is placed in the upper side of the carcass. Belts of these series are particularly suitable for troughing thanks to their high transversal flexibility.

SIDERFLEX HE are produced with two different layers placed on both sides of the warp structure. The presence of a double weft gives to the belt moderate transversal rigidity, anyway acceptable for the most common applications. HE serie is highly recommended when exceptional values of cut and tear resistance are required.

COVER SPECIFICATIONS

The main functions of rubber covers are the protection of the carcass against wear or damages during the running of the belt and the conveying of the material.

The cover thickness required for a specific belt is in function of the material conveyed and of the handling method used. Thicker covers are required if the following conditions become more severe:

- Material abrasiveness
- Lump size
- Material sharpness
- Height of drop into the belt
- Loading angle
- Belt speed and frequency of load

Here the suggested curves to estimate the correct cover thickness. Usually the bottom cover is half the top.

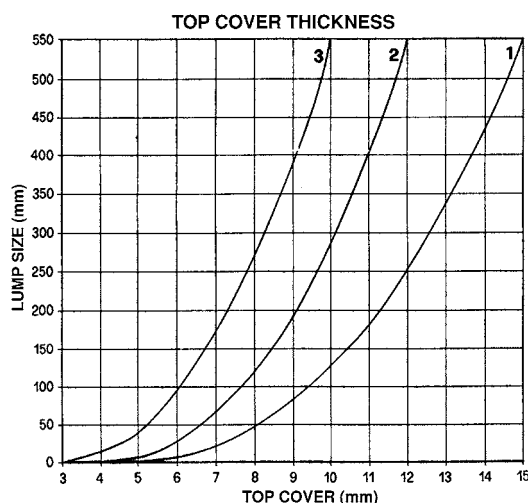

- 1 = Very sharp, hard (e.g. granite)
- 2 = Angular, irregular (e.g. limestone)
- 3 = Round, light (e.g. coal)

ABRASION SERVICE

CL Belts produced with this cover are recommended for all above ground applications where the resistance to abrasion is required. It is designed for the handling of heavy and abrasive materials such as gravel, crushed stones, sand, coal, cement, limestone, phosphate, salt, potash, etc.

Grade L ISO 10247 – Grade Y DIN 22102 - RMA 2

EC Belts produced with this particular compound are of superior quality especially for abrasion. The characteristics of resistance against cut, tear, abrasion, ozone cracking, together with long duration, improve the quality of this cover.

Grade D ISO 10247 – Grade W DIN 22102 - RMA 1

HEAT RESISTANT

CX This cover assures a medium degree of abrasion resistance and is formulated for continuous service of hot materials at temperature of 130 °C (270 °F) with peaks of up to 150 °C (300 °F). It is recommended for hot materials such as clinker, coke, hot scraps, fly ash, etc.

SELFEEXTINGUISH

BS This cover is designed to serve applications where safety is important and the fire risk is high. It is recommended for coal, potash, sulphure.

According to ISO 340, ISO 284, DIN 22103, DIN 22104.

For special requirements please contact our commercial dept.

PRODUCT PROPERTIES

ELONGATION & CREEP

These mechanical properties refer to the elastic characteristics of cords and to our method of production defined to obtain the best performances of the final product.

Low elongation is one of the most important points of SIDERFLEX belts: laboratory tests made on rubber-coated cords give value of elongation as shown in the following table:

SIDERFLEX serie	Elongation at reference load	Elongation at breaking load
IW-HE	0,40 %	4 %
ID	0,25 %	2 %

Reference load: 10% of nominal tensile strenght

Creep is the permanent elongation that the belt shows in the first period of life. The great advantage of SIDERFLEX in comparison with textile belts is a very reduced creep, generally negligible. This property helps maintenance because the belt can be vulcanized just one time on original installation without need of new joint after a certain period of time.

CUT & TEAR RESISTANCE

Longitudinal cuts and tears are always a cause of belt replacements both in textile and conventional steel cord belts. SIDERFLEX, with its steel weft, is more resistant against this kind of damages.

Indicative values of cut resistance in kN for SIDERFLEX IW belts compared with multiply textile belts are shown in the following table:

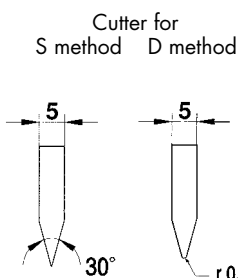

Belt range	S method		D method	
	IW	EP	IW	EP
500	2,5	0,8	4,8	2,5
630	2,8	0,9	5,1	2,8
800	3,4	1,0	6,5	3,4
1000	3,6	1,2	6,7	3,9
1250	3,8	1,3	8,0	4,2
1600	3,8	1,5	8,0	4,6

IMPACT RESISTANCE

SIDERFLEX has high impact resistance. The effect of oversized material falling on to the belt at the loading point is absorbed by the flexible steel carcass and the high quality level of rubber used.

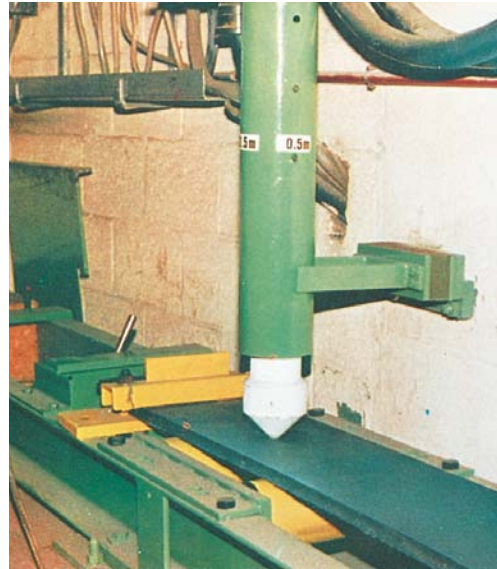

CORROSION PREVENTION

Various properties of our SIDERFLEX assure a superior resistant against corrosion of steel cord:

- The adhesion between steel cord and core rubber is obtained through a chemical reaction during the curing process between special chemical compounds present in the rubber and brass (Cu/Zn alloy) covering the cords. In comparison with other coating method (typically Zn), brass assures an higher and more constant adhesion to rubber.
- The open cord construction for IW, HE carcass and the special design of regular cord used for ID carcass allow the penetration of rubber up to the center of the cords, virtually eliminating the capillary action of moisture.

Regular 7x7 steel cords
SIDERFLEX ID

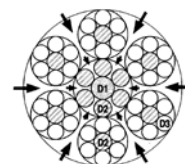

Open steel cords
SIDERFLEX IW-HE

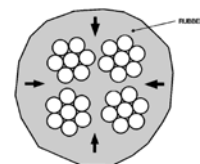

- During the vulcanizing process, the combined effect of heat and pressure produces the flowing of rubber into the cord center and the top and bottom cover become "one" with the steel carcass locked in the center. In conclusion, no ply separation is allowed.

EQUIPMENT DESIGN

LONGITUDINAL FLEXIBILITY

The presence of a single ply and the special warp cords construction give to the SIDERFLEX IW & HE belts a considerable longitudinal flexibility.

At the same condition of fatigue stress this properties allows to use smaller pulleys than equivalent textile multi-ply.

It means that in existing plants it is generally possible to replace the original textile belts with SIDERFLEX IW & HE without any plant modification.

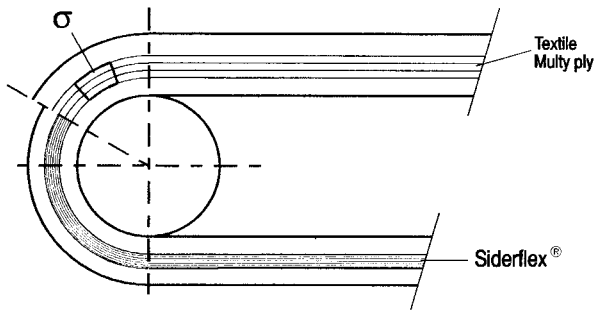

TROUGHABILITY

For a long time the majority of trough idlers have been produced with angle of around 20°.

Due to the increasing demand for higher handling capacity, the angle of the idlers went up in value reaching 30-35° and even more.

SIDERFLEX belts, in all series and style, thanks to their transversal flexibility will trough perfectly up to 60° without any problem.

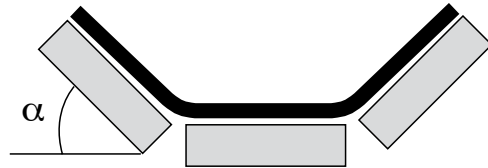

Here below, the table shows for each width of SIDERFLEX IW the corresponding maximum inclination angle according to ISO 703 and our practical experience.

Belt width	α max
650	45°
800	55°
1000	> 60°
1200	> 60°

For widths over 1200 mm, the test has not practical meaning.

TAKE-UP TRAVEL

According to the indications of project ISO 3870, the minimum suggested take-up travel is defined in the following table as a percentage of the center distance.

Type of Take-up	Type of carcass		
	ID	IW-HE	Polyester (EP)
Screw take-up device	0,3%	0,6%	2,5%
Screw take-up device (with tension indicator)	0,3%	0,5%	2,0%
Automatic tensioning device	0,3%	0,5%	2,5%
Automatic tensioning device (with pretensioning before the joining)	0,3%	0,5%	2,0%

SIDERFLEX MAIN PRODUCTION

CARCASS SPECIFICATION

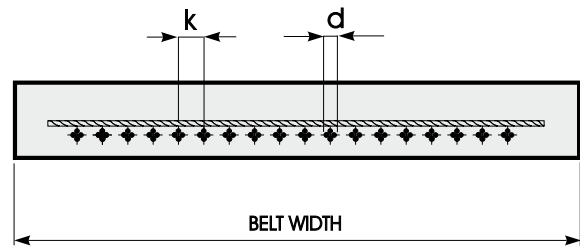
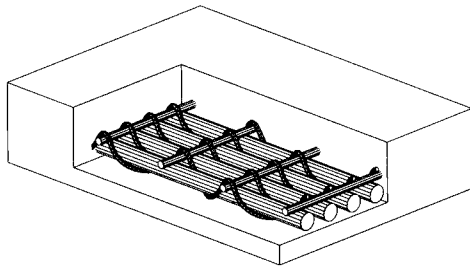

SIDERFLEX IW

SINGLE STEEL WEFT

IW SERIE		800	1000	1250	1400	1600	1800	2000
Tensile strength	N/mm	800	1000	1250	1400	1600	1800	2000
Cord pitch (k)	mm	6,7	5,4	7,0	6,2	5,5	8,3	7,8
Cord density	Cords/m	150	186	142	160	182	120	128
Cord diameter (d)	mm	2,8	2,8	3,9	3,9	3,9	4,3	4,3
Weft cord diameter	mm	2,0	2,0	2,4	2,4	2,4	2,4	2,4
Weft cord pitch	mm	20,0	20,0	20,0	20,0	20,0	20,0	20,0

Minimum cover thickness 6+4 mm

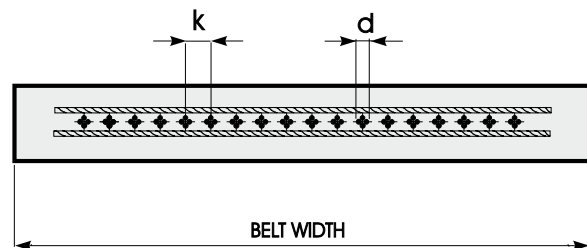
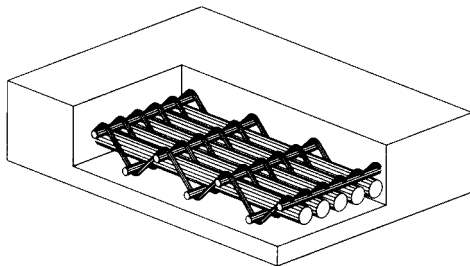

SIDERFLEX HE

DOUBLE STEEL WEFT

HE SERIE		800	1000	1250	1400	1600	1800	2000	2500	2750
Tensile strength	N/mm	800	1000	1250	1400	1600	1800	2000	2500	2750
Cord pitch (k)	mm	6,7	5,4	7,0	6,3	5,5	5,0	4,7	6,3	5,7
Cord density	Cords/m	150	186	142	160	182	200	215	158	175
Cord diameter (d)	mm	2,8	2,8	3,9	3,9	3,9	3,9	3,9	4,3	4,3
Weft cord diameter	mm	1,5	1,5	2,0	2,0	2,0	2,0	2,0	2,0	2,0
Weft cord pitch	mm	12,5	12,5	15,0	15,0	15,0	12,5	12,5	12,5	12,5

Minimum cover thickness 6+3 mm

PULLEYS

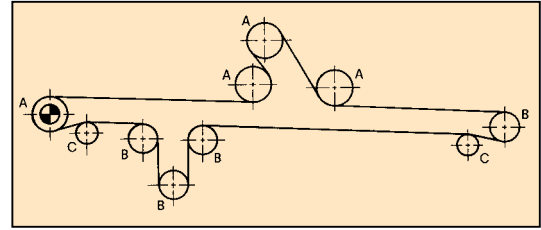

MINIMUM RECOMMENDED PULLEYS DIAMETER (mm)

Belt range N/mm	Ratio of working tension against recommended max belt tension								
	Between 60 % and 100 % <i>Safety factor between 8 and 13</i>			Between 30 % and 60 % <i>Safety factor between 13 and 27</i>			Up to 30 % <i>Safety factor over 27</i>		
	TYPE OF PULLEY								
	A	B	C	A	B	C	A	B	C
SIDERFLEX IW & HE – FINGER JOINT METHOD									
800	500	400	315	400	315	250	315	315	250
1000	500	400	315	400	315	250	315	315	250
1250	630	500	400	500	400	315	400	400	315
1400	630	500	400	500	400	315	400	400	315
1600	630	500	400	500	400	315	400	400	315
1800*	630/800	500/630	400/500	500/630	400/500	315/400	400/500	400/500	315/400
2000*	630/800	500/630	400/500	500/630	400/500	315/400	400/500	400/500	315/400
2500	800	630	500	630	500	400	500	500	400
2750	800	630	500	630	500	400	500	500	400

The above values are valid only for finger joint method. Different methods can increase the joint rigidity and consequently need different higher pulley diameters.

* First value for HE, secondo for IW type.

JOINTS

In addition to the already mentioned outstanding technical characteristics, SIDERFLEX belts can be easily jointed in a relatively short time using selected well skilled people.

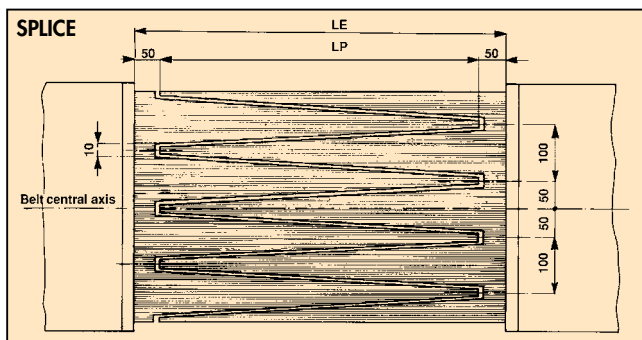
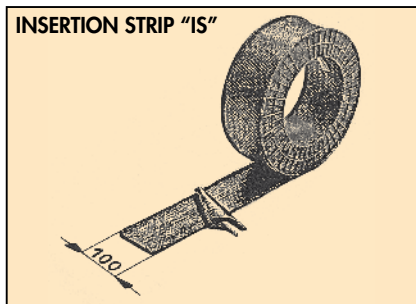

The possible types of joints for SIDERFLEX IW & HE belts are the following:

- **Finger joint:** the most frequent and efficient type of joint. If well done, it can reach the same tensile strength of steel cord belt. For further details, see the description here below.
- **Insertion joint:** faster than the previous but it will increase the joint rigidity; it is only recommended with pulley diameters bigger than the suggested values of the previous table.
- **Mechanical fastener joint:** it can be used for short time for easy joint and repair. Recommended only for HE serie.

The joint method here described assures an excellent level of flexibility of the joint area as there are not reinforcing elements placed parallel to the longitudinal axis of the belt.

The joint is prepared removing top cover, bottom cover and transversal cords and cutting the longitudinal cords with special shears or nippers. The joint elements from each side are connected together as shown in the drawing. Over the fingers, one or two layers of IS are transversally placed covering the whole splice surface. The presence of IS is necessary to joint the fingers among them through the rubber layer placed between cords and IS.

SIDERFLEX CONVENTIONAL PRODUCTION

CARCASS SPECIFICATION

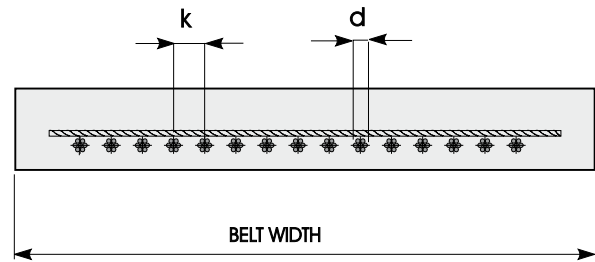
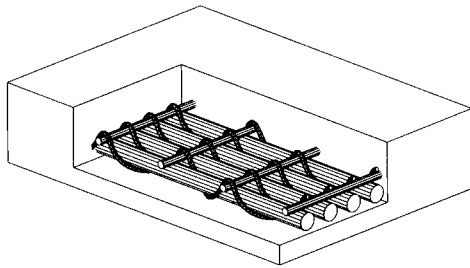

SIDERFLEX ID

SINGLE STEEL WEFT

ID SERIE		800	1000	1250	1400	1600	1800	2000	2500	3150
Tensile strength	N/mm	800	1000	1250	1400	1600	1800	2000	2500	3150
Cord pitch (k)	mm	15	12	14	13	15	13	12	15	15
Cord density	Cords/m	67	83	71	77	67	77	83	67	67
Cord diameter (d)	mm	3,6	3,6	4,4	4,4	5,2	5,2	5,2	6,9	7,6
Weft cord diameter	mm	2,0	2,0	2,0	2,0	2,0	2,0	2,0	2,0	2,0
Weft cord pitch	mm	14,0	14,0	14,0	14,0	14,0	14,0	14,0	14,0	14,0

Minimum cover thickness 8+4 mm

Comparison table between SIDERFLEX ID and (ex) DIN 22131/ISO 15236-2 Type A1

Belt range	800	1000	1250	1400	1600	1800	2000	2500	3150
CORDS DIAMETER - d (mm)									
ID	3,6	3,6	4,4	4,4	5,2	5,2	5,2	6,9	7,6
DIN	N.A.	Max 4,2	Max 4,9	N.A.	Max 5,6	Max 5,6	Max 5,6	Max 7,2	Max 8,1
CORD PITCH - k (mm)									
ID	15	12	14	13	15	13	12	15	15
DIN	N.A.	12	14	N.A.	15	N.A.	12	15	15
MINIMUM CORD TENSILE STRENGTH (N)									
ID	13500	13500	19800	19800	26700	26700	26700	41200	51200
DIN	N.A.	12900	18400	N.A.	26200	N.A.	25500	39700	50000

PULLEYS

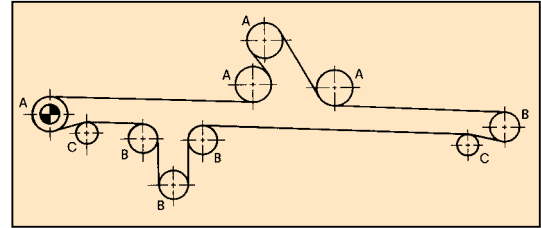

MINIMUM RECOMMENDED PULLEYS DIAMETER (MM)

Belt range N/mm	Ratio of working tension against recommended max belt tension								
	Between 60 % and 100 % <i>Safety factor between 8 and 13</i>			Between 30 % and 60 % <i>Safety factor between 13 and 27</i>			Up to 30 % <i>Safety factor over 27</i>		
	TYPES OF PULLEY								
	A	B	C	A	B	C	A	B	C
SIDERFLEX ID – DIN 22131 JOINT METHOD									
800	630	500	400	500	400	315	400	400	315
1000	630	500	400	500	400	315	400	400	315
1250	800	630	500	630	500	400	500	500	400
1400	800	630	500	630	500	400	500	500	400
1600	800	630	500	630	500	400	500	500	400
1800	800	630	500	630	500	400	500	500	400
2000	800	630	500	630	500	400	500	500	400
2500	1000	800	630	800	630	500	630	630	500
3150	1250	1000	800	1000	800	630	800	800	630

JOINTS

SIDERFLEX ID must be jointed according to the instructions of (ex) DIN 22131. The cords of the two belt ends must be free from the rubber and set down parallel in an althernate pattern in accordance with one of the drawing in the right in relation to the cord diameter and pitch: 1 step joint up to style 1600 N/mm, 2 step joint for higher styles. All the joint area must be fullfilled by uncured rubber. As in the joint the cords of the two belt ends are not mechanically connected, this rubber after the vulcanization is the only element that guarantees the strength transmission between the cords of the two ends.

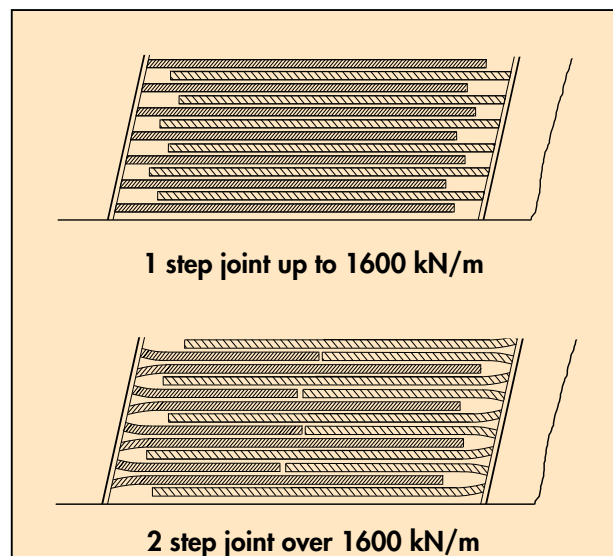

TRANSITION DISTANCE

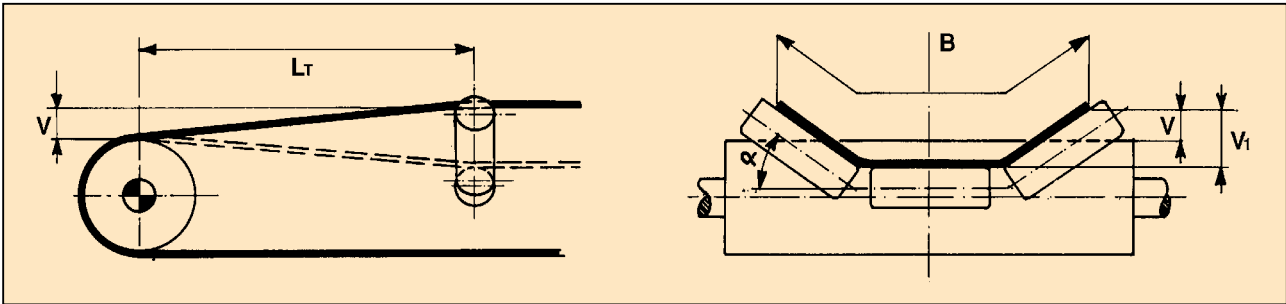

The transition distance is the length of the section between head or tail pulley and the first troughing idler. In some cases, intermediate idlers placed along the transition distance make easier the passage of the belt from the flat to the trough shape.

These conveyor sections are the most critical points of the whole plant as the elastic performances of the belt during the time depend on them.

If the transition distance is not correctly designed, high overtensions on the edges and abnormal compressions along the central axis of the belt are generated. Such phenomenon are the cause of defects, sometimes wrongly blamed to the belt as waves on the edges and longitudinal fold of the belt carcass.

According to the recommendation of ISO 5293/81, the calculation of the transition distance is performed in order to avoid belt centre from buckling and edge tension from exceeding 30% of the maximum recommended belt tension (RMBT).

These conditions can be respected using the following formula:

$$L_T = d \times V \times K$$

where $d = 20,4$ for SIDERFLEX IW-HE
 $28,9$ for SIDERFLEX ID

Experimental trials, calculations and experiences have shown that average conditions of tension and compression are carried out with values of V equal to $1/2 V_1$.

Nevertheless, with larger sizes there is the tendency of backward rolling of the materials and in most cases values of V included between $2/3$ and $4/5$ of V_1 are assumed.

For SIDERFLEX IW & HE, the values of the transition distance L_T can be easily calculated, with idlers of equal length, through the following formula:

$$L_T = L_1 \times B \times K$$

where:

L_1 = unitary transition distance (see table below)

B = Belt width

K = reduction factor depending on the working tension on the belt.

UNITARY TRANSITION DISTANCE L_1

$V =$	Idler inclination				
	20°	$27 \frac{1}{2}^\circ$	30°	35°	45°
V_1	2,32	3,15	3,41	3,90	4,81
$4/5 V_1$	1,86	2,51	2,71	3,12	3,85
$3/4 V_1$	1,75	2,35	2,55	2,93	3,61
$2/3 V_1$	1,54	2,09	2,27	2,60	3,20
$1/2 V_1$	1,17	1,57	1,70	1,95	2,41

'K' FACTOR

% RMBT	1	0,9	0,8	0,7	0,6	0,2	0,1	0,05
K multiplier factor	1	0,93	0,82	0,74	0,71	0,83	1,22	1,74

RMBT = Recommended Maximum Belt Tension

TECHNICAL DATA SHEET

CUSTOMER: DATE:
 REQUIRED BELT:

MATERIAL CHARACTERISTIC

Material: Temperature Surcharge angle:°
 Density: Ton/m³ Average: °C Abrasiveness
 Lump size: mm Max: °C Low Medium High

CONVEYOR DATA

Center distance: m Design capacity: T/h Speed: m/sec
 Width: mm Average capacity: T/h Elevation: m
 Radius of curve (if present): If there are more than one vertical curve please enclose quoted drawing
 Max tension T₁: KN/m Min tension T₂: KN/m

DRIVE UNIT

Position of drive pulley(s) Head Tail Return side Total wrap:°
 Drive pulley surface Steel Rubber Ceramic
 Applied power: KW Starting device:

IDLERS

	Inclination	Pitch	Diameter
Carrying side° mm mm
Return side° mm mm
Sliding plane

PULLEY DIAMETER AND TRANSITION DISTANCE

Drive pulley	Head pulley	Tail pulley	Take-up pulley	Tripper pulley
..... mm mm mm mm mm

TAKE-UP

Screw Take-up travel: m
 Counterweight Applied counterweight: kg
 Winch Position (distance from head): m

JOINT

DISCHARGE

Vulcanized Mechanical fasteners Tail Lateral
 Type: Tripper Tripper elevation: m

PREVIOUS BELT

Type	Tensile strength	N° of plies	Cover thickness	Cover quality	Width
..... kN/m + mm mm
.....	Cord diameter	Nr. of cords	Cord pitch	Total thickness
..... mm mm mm mm

Manufacturer: Lifetime:
 Cause of failure:



THE MATTER OF THIS PUBLICATION IS ONLY FOR INFORMATION; THEREFORE IT CAN NOT INVOLVE S.I.G. FOR ANY CONSEQUENCES DUE TO POSSIBLE ERRORS.

S.I.G. RESERVES THE RIGHT TO INTRODUCE AT ANY TIME SUCH MODIFICATION AS COULD BE JUSTIFIED BY CONTINUAL DEVELOPMENT AND IMPROVEMENT.

05/14 Rev. 3



ISO 9001:2000 QUALITY SYSTEM CERTIFICATION

21055 Gorla Minore (Italy)

Via Colombo, 144

Phone +39 0331 36.51.35

Fax +39 0331 36.52.15

www.sig.it - E-Mail: sig@sig.it

